

Technical characteristics

- Flow rates: from 1.5 to 304 l/h
- Max Pressure: up to 25 bar (363 psi)
- Motor:
 - 0.18 kW and 0.25 kW - 3 ph (IP55)
 - 0.25 kW and 0.37 kW - 1 ph (IP55)
- Stroke rate: 58 –116 strokes/minute
- Stroke length: 15 mm
- Piston diameter: from 6 to 64 mm
- Pump head:
 - SS 316 L
 - PVC
- Max. dosing temperature:
 - SS 316 L 90 °C
 - PVC 40 °C
- Ambient dosing temperature:
 - +5 ÷ +45 °C
- Stacking temperature:
 - -10 ÷ +50 °C

Seko plunger piston pump PS1 Series has a wide range product. PS1 Series performances cover s from 1.5 to 304 l/h with a back pressure up to 25 bar, having several configurations available for the pump head and power, in order to have the characteristics most suitable for processes where required. PS1 pump have a spring return mechanism into an aluminum housing.

Each model has 2 values of stroke rate, which can be set manually or automatically using an actuator which accepts a signal 4÷20 mA. Moreover they can be supplied with a 3 phases or 1 phase electric motor with protection class IP55.

PUMP KEY CODE

Field 1	Field 2	Field 3	Field 4	Field 5	Field 6	Field 7	Field 8	Field 9	Field 10
P	S1	D	011	C	31	A4	L	0	0

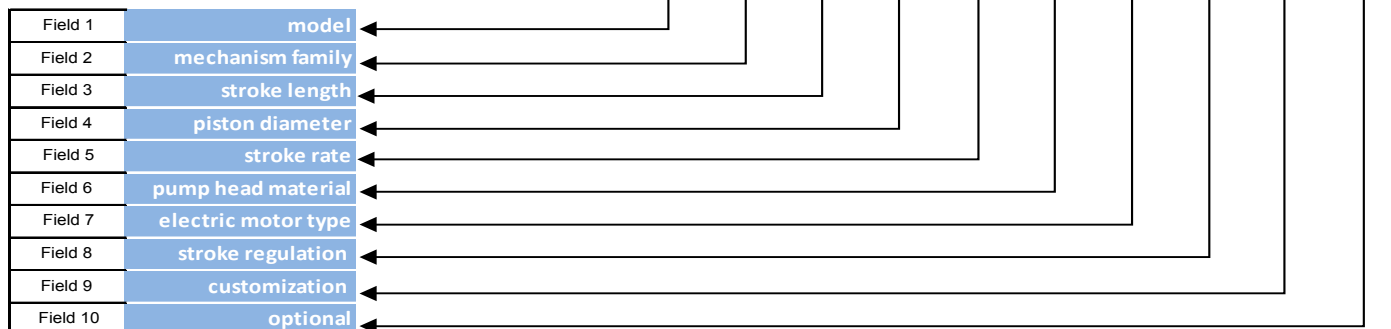

Field 1	model	P	<i>Plunger Piston</i>
---------	-------	----------	-----------------------

Field 2	mechanism family	S1	<i>Piston</i>
---------	------------------	-----------	---------------

Field 3	stroke length	D	<i>15 [mm]</i>
---------	---------------	----------	----------------

Field 4	piston diameter	006	<i>6 [mm]</i>
		011	<i>11</i>
		017	<i>17</i>
		025	<i>25</i>
		030	<i>30</i>
		038	<i>38</i>
		048	<i>48</i>
		054	<i>54</i>
		064	<i>64</i>

Field 5	stroke rate	A	<i>58 [stroke/1']</i>
		C	<i>116</i>

Field 6	pump head material		<i>head</i>	<i>piston</i>	<i>pist. seal</i>	<i>valves</i>	<i>seat valves</i>	<i>O-Ring</i>	
		21	SS316	SS316	FPM	SS316	SS316	FPM	<i>on Ø 6 - 11</i>
		31	PVC	CERAMIC	FPM	CERAMIC	PTFE	FPM	<i>on Ø 17 - 25 - 30 - 38</i>
		24	SS316	CERAMIC	EPDM	SS316	SS316	EPDM	<i>on Ø 6 - 11</i>
		32	PVC	CERAMIC	FPM	SS316	SS316	FPM	<i>on Ø 17 - 25 - 30 - 38</i>
		34	PVC	CERAMIC	EPDM	CERAMIC	PTFE	EPDM	<i>on Ø 17 - 25 - 30 - 38</i>

Field 7	electric motor type	A4	<i>0,18 kW</i>	<i>(4 poles - 3phases 230-400 Vac 50/60 Hz - size 63-B14)</i>
		B4	<i>0,25 kW</i>	<i>(4 poles - 3phases 230-400 Vac 50/60 Hz - size 71-B14)</i>
		H4	<i>0,25 kW</i>	<i>(4 poles - 1phase 230 Vac 50 Hz - size 71-B14)</i>
		I4	<i>0,37 kW</i>	<i>(4 poles - 1phase 230 Vac 50 Hz - size 71-B14)</i>
		AI	<i>0,18 kW</i>	<i>(4 poles - 3phases 230-400 Vac 50/60 Hz - size 63-B14 - with INVERTER)</i>
		BI	<i>0,25 kW</i>	<i>(4 poles - 3phases 230-400 Vac 50/60 Hz - size 71-B14 - with INVERTER)</i>
		S0	<i>WITHOUT motor</i>	

Field 8	stroke regulation	0	<i>Manual adjustment with knob - STANDARD</i>	
		L	<i>Automatic Linear Actuator AKTUA series</i>	

Field 9	customization	0	<i>Standard</i>	
		H	<i>High Pressure</i>	

Field 10	optional	0	<i>Standard</i>	
		2	<i>(S0 - WITHOUT motor) + adapter kit</i>	

HYDRAULIC CHARACTERISTICS

Pump Model	Piston Diameter [mm]	Stroke/min	Flow rate		Max back pressure				Suction/Discharge Connection		Electric Motor 50/60 Hz 3 phases [kW]
					bar		p.s.i.				
			l/h	gl/h	SS 316	PVC	SS 316	PVC	SS 316	PVC	
P S 1 D 0 0 6 A	6	58	1,5	0,40	20	10	290	145	1/4" G F	1/4" G F	0,18 (A4)
P S 1 D 0 0 6 C		116	3	0,79							
P S 1 D 0 1 1 A	11	58	5	1,32	20	10*	290	145*	1/4" G F	1/4" G F	0,18 (A4)
P S 1 D 0 1 1 C		116	10	2,64							
P S 1 D 0 1 7 A	17	58	11	2,90	20	10*	290	145*	3/8" G F	3/8" G F	0,18 (A4)
P S 1 D 0 1 7 C		116	22	5,81							
P S 1 D 0 2 5 A	25	58	25	6,60	20	10*	290	145*	3/8" G F	3/8" G F	0,18 (A4)
P S 1 D 0 2 5 C		116	50	13,21							
P S 1 D 0 3 0 A	30	58	35	9,25	20	10*	290	145*	3/8" G F	3/8" G F	0,25 (B4)
P S 1 D 0 3 0 C		116	70	18,49							
P S 1 D 0 3 8 A	38	58	55	14,53	17	10*	247	145*	3/8" G F	3/8" G F	0,25 (B4)
P S 1 D 0 3 8 C		116	110	29,06							
P S 1 D 0 4 8 A	48	58	85	22,45	10	10	145	145	1/2" G F	1/2" G F	0,25 (B4)
P S 1 D 0 4 8 C		116	170	44,91							
P S 1 D 0 5 4 A	54	58	110	29,06	8	8	116	116	1/2" G F	1/2" G F	0,25 (B4)
P S 1 D 0 5 4 C		116	220	58,12							
P S 1 D 0 6 4 A	64	58	152	40,15	6	4	87	58	3/4" G F	3/4" G F	0,25 (B4)
P S 1 D 0 6 4 C		116	304	80,31							

*Available with special reinforced pump head for use with pressure up to 20 bar - 9' Field (Optional) in the Key Code identified by "H"

DIMENSIONS

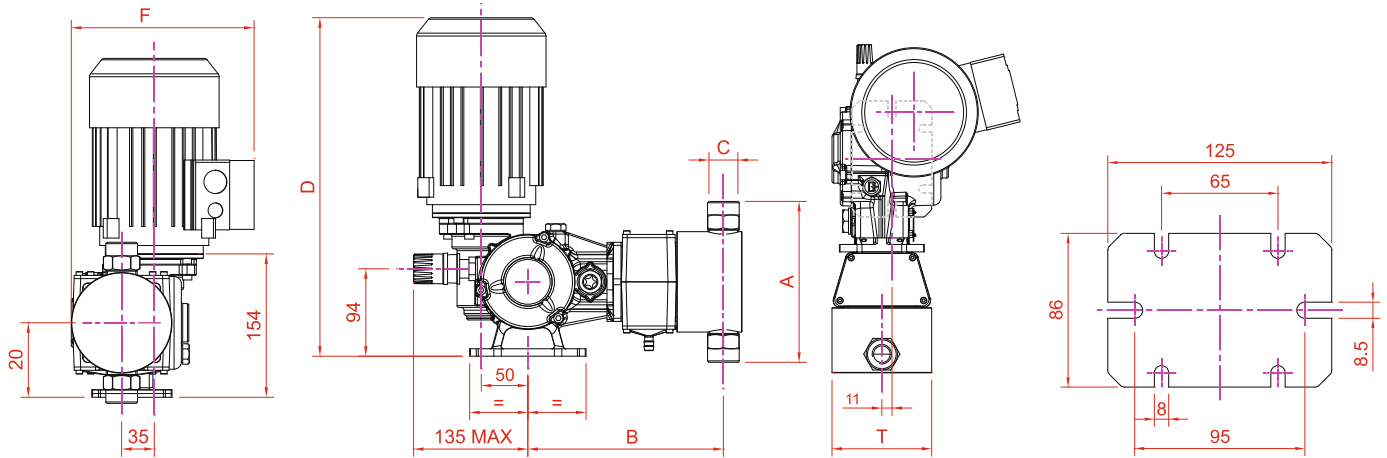

Materiale testata Liquid end material	Diametro pistone Plunger diameter	A[mm]	B[mm]	C (BSP)	T[mm]	Three phase					Single phase				
						Motore 4P Motor 4P [kW]	Gr. motore Motor Size	D[mm]	E[mm]	F[mm]	Motore 4P Motor 4P [kW]	Gr. motore Motor Size	D[mm]	E[mm]	F[mm]
AISI316 (21)	6	161	195	1/4" f	68	0.18	63 B14	333	362	206	0.25	71 B14	371	392	220
	11	161	195	1/4" f	68	0.18	63 B14	333	362	206	0.25	71 B14	371	392	220
	17	121	195	3/8" f	68	0.18	63 B14	333	362	206	0.25	71 B14	371	392	220
	25	121	200	3/8" f	68	0.18	63 B14	333	367	206	0.25	71 B14	371	397	220
	30	122	200	3/8" f	68	0.25	71 B14	371	378	215	0.37	71 B14	371	397	220
	38	164	210	3/8" f	88,5	0.25	71 B14	371	390	215	0.37	71 B14	371	409	220
	48	164	210	1/2" f	88,5	0.25	71 B14	371	390	215	0.37	71 B14	371	409	220
	54	176	210	1/2" f	108	0.25	71 B14	371	392	215	0.37	71 B14	371	411	220
PVC (31)	6	195	215	3/4" f	103	0.25	71 B14	371	401	215	0.37	71 B14	371	420	220
	6	220	195	1/4" f	79	0.18	63 B14	333	368	206	0.25	71 B14	371	398	220
	11	220	195	1/4" f	79	0.18	63 B14	333	368	206	0.25	71 B14	371	398	220
	17	179	195	3/8" f	79	0.18	63 B14	333	368	206	0.25	71 B14	371	398	220
	25	179	200	3/8" f	78	0.18	63 B14	333	377	206	0.25	71 B14	371	407	220
	30	178	200	3/8" f	78	0.25	71 B14	371	388	215	0.37	71 B14	371	407	220
	38	200	210	3/8" f	98	0.25	71 B14	371	402	215	0.37	71 B14	371	421	220
	48	244	210	1/2" f	108	0.25	71 B14	371	403	215	0.37	71 B14	371	422	220
54	253	210	1/2" f	118	0.25	71 B14	371	403	220	0.37	71 B14	371	422	225	
64	273	215	3/4" f	120	0.25	71 B14	371	413	220	0.37	71 B14	371	432	225	

